

EDGESHIELD DRIP EDGE

Edge Metal Series

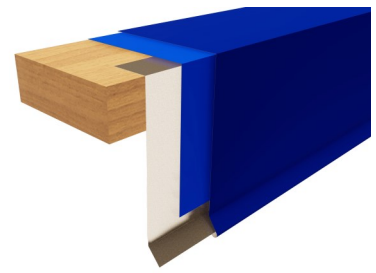

DIAGRAM

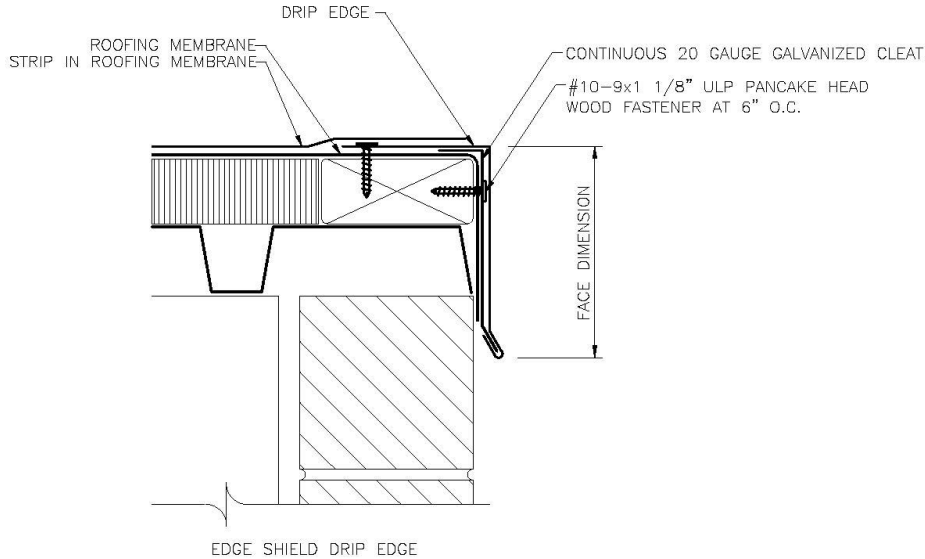

Material Options

24 ga. (0.63 mm) galvalume steel
22 ga. (0.76 mm) galvalume steel
24 ga. (0.063 mm) stainless steel
.032" (0.8 mm) aluminum
.040" (1.0 mm) aluminum
.050" (1.2 mm) aluminum
.063" (1.5 mm) aluminum



International Building Code Requirement: 2003 IBC-1504.5: "Edge securement for low-slope roofs. Low slope membrane roof systems metal edge securement, except gutters, installed in accordance with Section 1507, shall be designated in accordance with ANSI/SPRI ES-1, except the basic wind speed shall be determined from Figure 1609."

Material Options

Standard Kynar 500 colors (see color chart for availability)
Custom Kynar colors
Plain galvanized steel or "paintgrip"
Mill finish aluminum
Anodized aluminum
2B finish stainless

PRODUCT FEATURES

- Applicable with most roofing systems
- Installation with continuous 20 gauge galvanized cleat which is designed to be thicker than the finished metal
- Pre-punched holes to ensure proper fastener placement
- Meets ANSI/APRI ES-1 standard
- International Building Code compliant
- Concealed splice plates are also available
- Flange dimension is custom fabricated by Metal Panel Systems to suit roofing system requirements
- Standard finish is PVDF fluoropolymer coating in 30 standard colors
- System includes a 35 year finish warranty