

# NS-100 PANEL

Standing Seam Series

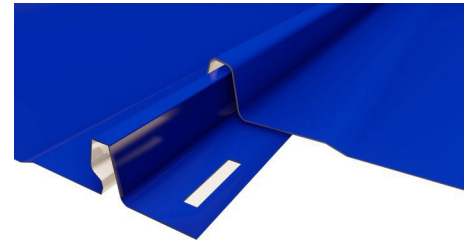

## OVERVIEW

The NS-100 Panel is a cost-effective concealed fastener panel with a continuous integral locking seam that does not require the use of separate clips.

## DIAGRAMS

**Seam Profile**

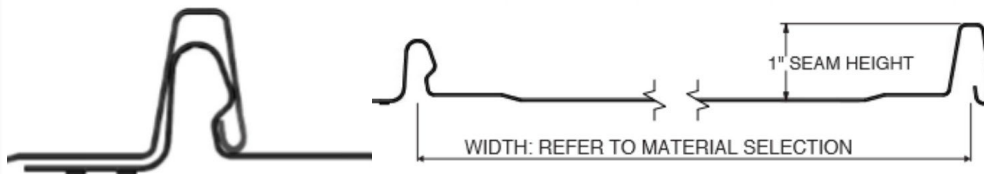

**Nail Strip Detail**

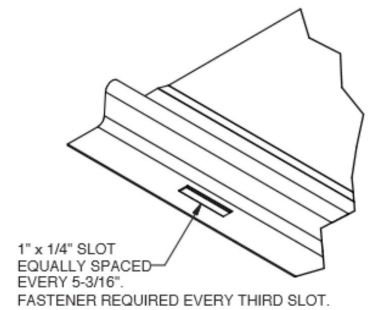

MATERIAL	STANDARD WIDTHS	OPTIONAL WIDTHS
<b>Silicone Modified Polyester Finish</b>		
26 ga. Steel	16"	12", 20"
<b>Kynar Finish</b>		
24 ga. Steel	16"	12", 20"
.032" Aluminum	16"	12", 20"
<b>Unfinished</b>		
26 ga. Galvalume	16"	12", 20"
24 ga. Galvalume	16"	12", 20"
16 oz. Copper	16"	12", 20"

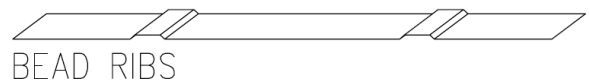
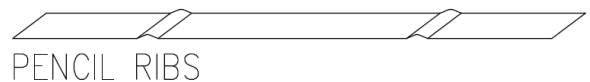
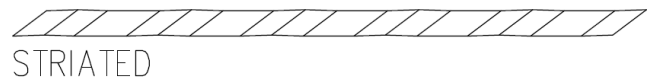

\*Aluminum & Copper available in limited quantities, please call for further availability

## PRODUCT FEATURES

- Architectural panel installed over solid substrate
- Integral snap-lock design provides continuous interlock at sidelap
- ANSI/UL 580 uplift resistance classified assembly
- Applicable for roof slopes as low as 3:12
- May also be utilized in vertical wall and fascia systems installations
- ANSI/UL 790 fire tested of roof coverings
- UL 2218 impact resistance tested
- No panel clips required (fasteners only)
- Standard silicone-modified polyester finish (30 year warranty) available in 12 standard colors
- Optional Kynar finish (35 year warranty) is available
- ANSI/UL 263 fire resistance rating